



Actuators for air dampers and gas dampers

SQM33...

Electromotoric actuators

- **Torques:**

- SQM33.4	up to 1.2 Nm	nominal output torque
- SQM33.5	up to 3 Nm	nominal output torque
- SQM33.7	up to 10 Nm	nominal output torque self-holding torque (refer to «Type summary»)
- **Running times for 90°:**

- SQM33.4	5 seconds
- SQM33.5	5 seconds
- SQM33.7	17 seconds
- **Versions:** Choice of cables (refer to «Type summary»)

The SQM33 and this Data Sheet are intended for use by OEMs which integrate the actuators in their products!

Use

The actuators SQM33 are suited for driving oil pressure controllers, butterfly valves, dampers or for use on other applications that require rotary motion. Areas of application are oil and gas burners of medium to larger capacity.

The actuators are used primarily for the load-dependent control of the flow of gas, oil volume, and combustion air volume in connection with the electronic ratio control LMV27 / LMV37.

Supplementary documentation

Product type	Type of documentation	Documentation number
LMV27.100x2	Basic Documentation	P7541
LMV37.400x2	Basic Documentation	P7546
AZL2	Data Sheet	N7542

Warning notes



To avoid injury to persons, damage to property or the environment, the following warning notes must be observed!

Do not open, interfere with or modify the actuators!

- Read the documentation on the actuators carefully and fully. If not observed, dangerous situations can occur
- The user must ensure that the actuators meet the requirements of the relevant application standards
- All product-related activities (mounting, settings and maintenance) must be performed by qualified and authorized personnel



Notice!

- **Risk of electric shock hazard – to disconnect the equipment from the power, it may be necessary to open more than one switch. Before performing maintenance work, the equipment must be disconnected from power**
- **The electrical connection between the conduit fittings is not made automatically. It must be established on installation site**
- **The connecting plate is made of plastic and does not provide earthing of the conduit fittings. Earthing must be ensured with adequate washers and wire links**

- Ensure protection against electric shock hazard by providing adequate protection for the connection terminals and by securing the housing cover
- To ensure protection against electric shock, the connection terminals must have adequate protection. Make certain that noninsulated connections or wires cannot be touched
- Each time work has been carried out (mounting, installation, service work, etc.), check to ensure that wiring is in an orderly state
- Fall or shock can adversely affect the safety functions. Such units must not be put into operation, even if they do not exhibit any damage
- The notes in chapter *Section of actuator version, Positive connection and Unambiguous assignment* must be observed, for safeguarding of correct fuel / air ratio
- Static charges must be avoided since they can damage the electronic components on contact.

Recommended: Use ESD equipment

Housing cover



Caution!

The actuator's housing must not be opened. The actuator contains an optical feedback system.

Notes on use in North America

Only flexible conduits with relevant accessories may be used.

Selection of actuator version

- Select the type of actuator depending on the torque required for driving the controlling element
- Ensure that any other torque acting on the controlling element (e.g. torque due to the airflow produced by the burner's fan) is smaller than the actuator's self-holding torque when power not applied
- The mechanical design of the burner must be such that any inadmissibly high torque from outside acting on the controlling element will not lead to critical burner operation.

Example:

The airflow in the burner's air duct exerts a torque on the air damper's asymmetrical bearing so that the air damper will slightly travel towards the fully open position. This leads to a certain amount of excess air in the combustion process, which is less critical than lack of air

Mounting notes

- Ensure that the relevant national safety regulations are complied with and standard notes
- In the geographical areas where DIN regulations are in use, the requirements of VDE must be satisfied, especially DIN/VDE 0100, 0550 and DIN/VDE 0722
- Make certain that the actuator is not exposed to direct solar radiation
- The connection between actuator drive shaft and controlling element must be form-fitted (no mechanical play permitted)
- When mounting the actuator, ensure that the permissible axial and radial load acting on the bearing will not be exceeded
- When fitting the actuator to the controlling element, proceed as follows:
 1. Fit and secure the actuator.
 2. Connect the actuator's drive shaft to the controlling element by means of a coupling pin.

Positive connection

Caution!

Possible connection with drive shaft or hub:

- Drive shaft with flat edge and matching counter piece

To avoid inadmissible loads on the bearing caused by rigid coupling hubs, Siemens recommends using compensating coupling without mechanical play (e.g. metal bellows coupling).



- When sizing a drive shaft connection, consider that – during operation – the effective torque can exceed the actuator's rated torque:
 - Under optimum operating conditions, the actuator may deliver a higher torque
 - Mass moments of inertia (produced by rotating motor components and on the controlling element) can lead to sudden peak loads
- Siemens AG recommends to adequately oversize the drive shaft connection in relation to the actuator's rated torque
- The connection between actuator and burner or controlling element must be very rigid (no bending). This is of particular importance when using structures incorporating columns

Unambiguous assignment



Caution!

To prevent mix-up of actuators connected to the LMV2 / LMV3, these types of burner controls carry various reference marks. The burner must be designed such that, in the event of false connections, the relevant reference mark cannot be approached. For that purpose, mechanical stops are to be provided in the range «Stop open» and «Stop closed».

Cable

SQM33.41xA9 / SQM33.51xA9 / SQM33.71xA9:

- The actuators are supplied complete with attached connecting cable and plug

SQM33.550A9 / SQM33.750A9:

- The actuators are supplied with cable ready connected, complete with ferrules
- The 6-poles RAST2.5 / RAST3.5 connecting plug (included in scope of delivery)
- One-time bend when laying the cable: 2 x cable diameter

Mounting notes (cont'd)

IP54

To ensure degree of protection IP54 over the actuator's entire service life, the bearing of the drive shaft must be located such that it will not be directly exposed to water or dust.

Mounting notes (cont'd)

Working range of actuator

The actuator's working range consists of usable range and reference range. The usable range is specified on the type field. When mounting the actuator, the connected controlling element (e.g. air damper) must allow travel both in the reference range and the adjusted usable range. Reference ranges «Open» and «Close» differ. In the case of an actuator with **counterclockwise** direction of rotation, reference range «Close» lies between 0° and -7.7° , and reference range «Open» between 90° and 110.6° . To ensure precise positioning of the actuator on the burner, a positioning pin of 6 mm dia. must be fitted to the mounting surface (refer to detail **A** under «Dimensions»).

Direction of rotation:
Counterclockwise

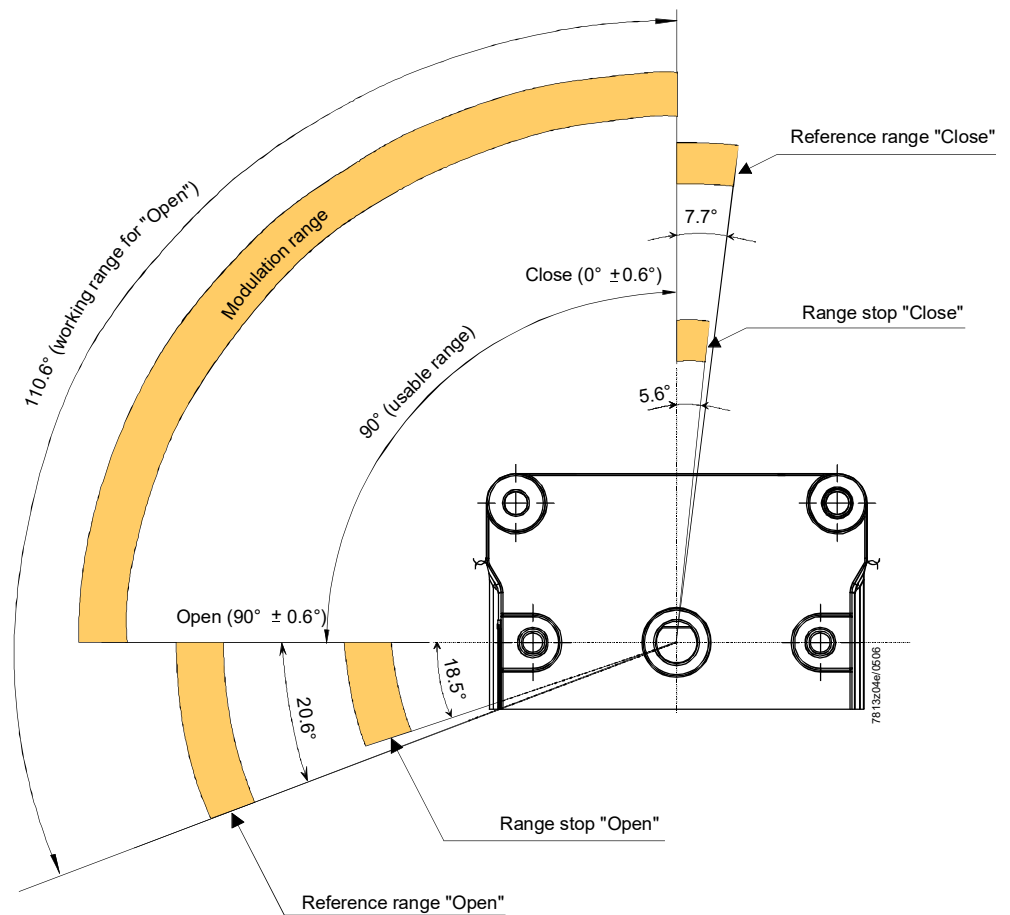

Mounting notes (cont'd)

Direction of rotation:

Clockwise

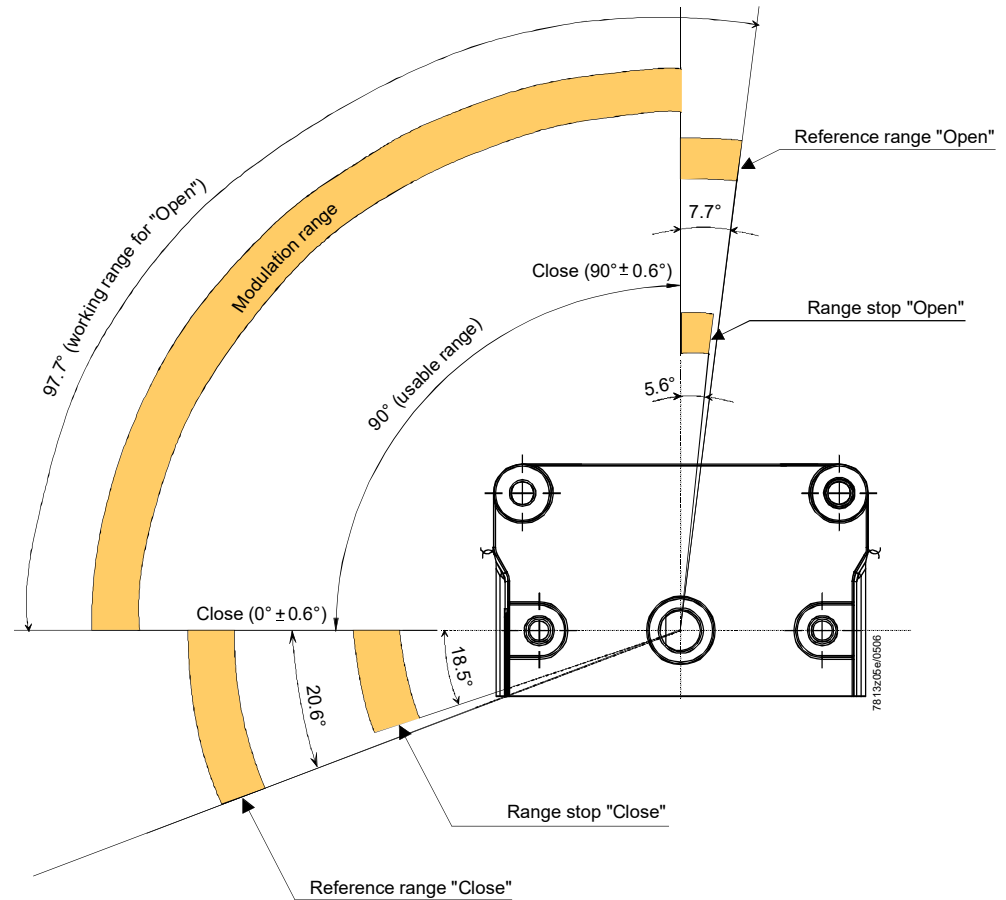

Installation notes

- Make certain that strain relief of the connected cables is in compliance with the relevant standards (e.g. in accordance with DIN EN 60730 and DIN EN 60335)
- The connection between the actuator drive shaft and the relevant controlling element must be form-fitted
- Always run the high-voltage ignition cables separate from the unit and other cables while observing the greatest possible distance
- The holding torque is reduced when the actuator is disconnected from power

Standards and certificates



Note!

Only in conjunction with the basic unit LMV2... / LMV3... (see Basic Documentation LMV2 → P7541 / LMV3 → P7546).



EAC Conformity mark (Eurasian Conformity mark)



ISO 9001:2015
ISO 14001:2015
OHSAS 18001:2007



China RoHS
Hazardous substances table:
<http://www.siemens.com/download?A6V10883536>



Service notes

Replacement

When replacing an actuator, the following points must be checked and, if necessary, corrected:

- Correct connection of the basic unit
- Assignment of functions
- Adjustment of curve points of electronic fuel / air ratio control (e.g. with the LMV27.100x2)

Lifetime

The actuator has a designed lifetime* of 250,000 start cycles (OFF ⇒ ON ⇒ OFF) under load with the rated torque in the entire rotation angle range, which under normal operating conditions in heating mode corresponds to approx. 10 years of service (starting from the production date given on the type field). This is based on the endurance tests specified in the standard EN 298. A summary of the conditions has been published by the European Control Manufacturers Association (Afecon) (www.afecor.org).

The designed lifetime is based on use of the actuator according to the manufacturer's data sheet. After reaching the designed lifetime in terms of the number of burner startup cycles, or after the corresponding usage time, the actuator is to be replaced by authorized personnel.

* The designed lifetime is not the warranty time specified in the Terms of Delivery.

Disposal notes

The actuator contains electrical and electronic components and must not be disposed of together with domestic waste. Local and currently valid legislation must be observed.

Mechanical design

Housing	<p>Die-cast aluminum lower housing. Housing cover made of impact-proof and heat-resistant plastic.</p> <p>SQM33.550A9 / SQM33.750A9 has a flange for the connection of a Conduit connecting thread (NPSM ½"-14).</p> <p>Color of cover: Black</p>
Drive motor	Stepper motor
Adjustment of switching points / position indication	In connection with the basic unit (e.g. LMV27.100x2): Via the AZL2 display and operating unit (refer to the Basic Documentation of the LMV27.100x2 (P7541)).
Cable / electrical connections	<p>SQM33.41xA9 and SQM33.51xA9 / SQM33.71xA9 only: RAST2.5 connectors complete with cable.</p> <p>SQM33.550A9 / SQM33.750A9 only: Cable with ferrules, RAST2.5 / RAST3.5 connector (included in scope of delivery).</p>
Gear train	Spur gears made of steel and plastic, with little backlash and permanent lubrication.
Drive shaft	Made of black-finished steel, ready fitted to the front of the gear train.
Mounting and fixing	The front of the gear train is used as the mounting surface. The actuator has 4 fixing holes and an elongated hole for the positioning pin. Alternatively, the actuator can be secured with 3 self-tapping screws from the side of the controlling element.

Type summary

Actuators SQM33

Article no.	Type	Rated output torque (max.) Nm ¹⁾	Holding torque when power applied (max.) Nm	Holding torque when power not applied (max.) Nm	Cable length m	Radial load on bearing middle of driveshaft (max.) N	Axial load on bearing middle of drive shaft (max.) N
BPZ:SQM33.410A9	SQM33.410A9	1,2	1,2	0,8	1,5	100	10
BPZ:SQM33.411A9	SQM33.411A9	1,2	1,2	0,8	3	100	10
S55451-D103-A100	SQM33.412A9	1,2	1,2	0,8	1,6	100	10
BPZ:SQM33.510A9	SQM33.510A9	3	3	2,6	1,5	100	10
BPZ:SQM33.511A9	SQM33.511A9	3	3	2,6	3	100	10
BPZ:SQM33.550A9	SQM33.550A9	3	3	2,6	3,6	100	10
BPZ:SQM33.711A9	SQM33.711A9	10	10	6	3	100	10
BPZ:SQM33.750A9	SQM33.750A9	10	10	6	3,6	100	10

¹⁾ For ambient temperatures below -15 °C and above 50 °C: Approx 10 % torque reduction

Accessories

Accessories must be ordered as separate items:



Proportional controlling element with mounting plate

VKP

Proportional controlling element for mounting between threaded flanges in gas trains
See Data Sheet N7632.



Butterfly valve

VKF1x

Butterfly valves designed in intermediate flange design, for mounting into gas trains.
Refer to Data Sheet N7673.



Mounting plate

ASK33.1

Article no.: **BPZ:ASK33.1**

For mounting the SQM33 on the VKP proportional controlling element or on the VKF1x butterfly valve.



Note

The required screws (3x M5 countersunk screws and 4x M5 screws) are included in the packaging for the ASK33.1.

Technical data

Actuator	Operating voltage	24 V \pm 20% (load on interface)
	Power consumption	
	• SQM33.4xxA9	Max. 7.5 W
	• SQM33.5xxA9 / SQM33.7xxA9	Max. 10 W
	Perm. on time	50%, max. 3 minutes continuously
	Angular adjustment, usable range	Between 0° and max. 90°
	Mounting position	Optional
	Load on bearing	Refer to «Type summary»
	Degree of protection	
	• SQM33.41xA9 / SQM33.51xA9	IP54 to EN 60 529-1
• SQM33.550A9 / SQM33.750A9	IP40 (at the cable outlet, with no conduit connected) IP54 can be achieved with conduit connected	

**Caution!**

The bearing of the driven shaft must be protected against direct hazard of water and dust via corresponding mounting. If not, IP54 cannot be ensured over the full life cycle.

Safety class	II to EN 60 730 part 1 and parts 2-14
Direction of rotation	Can be selected on the basic unit
Nominal output torque	Refer to «Type summary»
Holding torque (when power applied)	Refer to «Type summary»
Holding torque (when power not applied)	Refer to «Type summary»
Reproducibility (typically when new)	$\pm 0.2^\circ$ (when used with the basic units of the LMV27.100x2 / LMV37.400x2)
Nominal resolution encoder supervision	0.7°
Running times	Is determined by the basic unit
Weight	Approx. 1.4 kg
Direction of rotation (when facing the shaft)	
• Standard	Counterclockwise
• Reverse	Clockwise
0-position of actuator drive shaft	Supply state $0 \pm 0.6^\circ$
Temperature of the mounting surface	Max. 60 °C
Conduit connecting thread	
• SQM33.550A9	NPSM 1/2"-14 Usable depth of thread: Min. 10 mm
Life cycle	250,000 start cycles (CLOSE \Rightarrow OPEN \Rightarrow CLOSE) under load with the rated torque in the entire rotation angle range. 2,000,000 control cycles under load with 75% of rated torque in rotation angle range of 10°

Technical data (cont'd)

Cable connection	SQM33.41xA9 / SQM33.51xA9 / SQM33.71xA9	Duomodule RAST2.5 6-poles Supplied by Lumberg Part no. 3521 06 K00
	SQM33.55xA9 / SQM33.75xA9	Free from halogen UL-listed Black 6 5.5...6.5 mm AWG22 / 0.34 mm ² / 7 wires 1.45...1.6 mm Defined by UL (88A) -20...+70 °C <100 Ω / km >20 MΩ x km <50 V 50 Hz effective / 1 min >300 V >3.75 kV to DIN EN 60730, chapter 13 IP40 at cable exit without connected conduit
	• Connector	With screw terminal RAST3.5 6-poles Supplied by PTR Part no. AK 1550 as well as Duomodul plug connector RAST2.5 6-pole Supplier Lumberg Order number: 3521 06 K00
Environmental conditions	Storage	DIN EN 60721-3-1:1997
	Climatic conditions	Class 1K3
	Mechanical conditions	Class 1M2
	Temperature range	-20...+70 °C
	Humidity	<95% r.h.
	Transport	DIN EN 60721-3-2:1997
	Climatic conditions	Class 2K3
	Mechanical conditions	Class 2M2
	Temperature range	-20...+70 °C
	Humidity	<95% r.h.
	Operation	DIN EN 60721-3-3:1995
	Climatic conditions	Class 3K5
Mechanical conditions	Class 3M4	
Temperature range	-20...+60 °C	
Humidity	<95% r.h.	
Installation altitude	Max. 2,000 m above sea level	

**Caution!****Condensation, formation of ice and ingress of water are not permitted!****If this is not observed, there is a risk of loss of safety functions and a risk of electric shock.**

Function

The SQM33 actuators are of robust design and have a gear train with only little backlash. Control and position feedback take place via a common cable. The same cable is used for powering the actuator. The actuators are driven by stepper motors and can be positioned with a resolution of 0.1° . The characteristics and settings (running time, direction of rotation, end positions) of the SQM33 are determined by the controlling basic unit (e.g. LMV27.100x2; for details, refer to the Basic Documentation of the LMV27.100x2 (P7541)). The running times of the controlling elements are varied by the basic unit depending on the burner's control phase (e.g. startup phase: short running time; operation: long running time).



Application note!

Single-sided load torque is recommended due to the type of gear train for the SQM33.7xxA9 actuators. In the event of load on both sides, a backlash of $\pm 0.3^\circ$ must also be considered in addition to plant design or setting.

Dimensions

Dimensions in mm

SQM33.41xA9 / SQM33.51xA9 / SQM33.71xA9

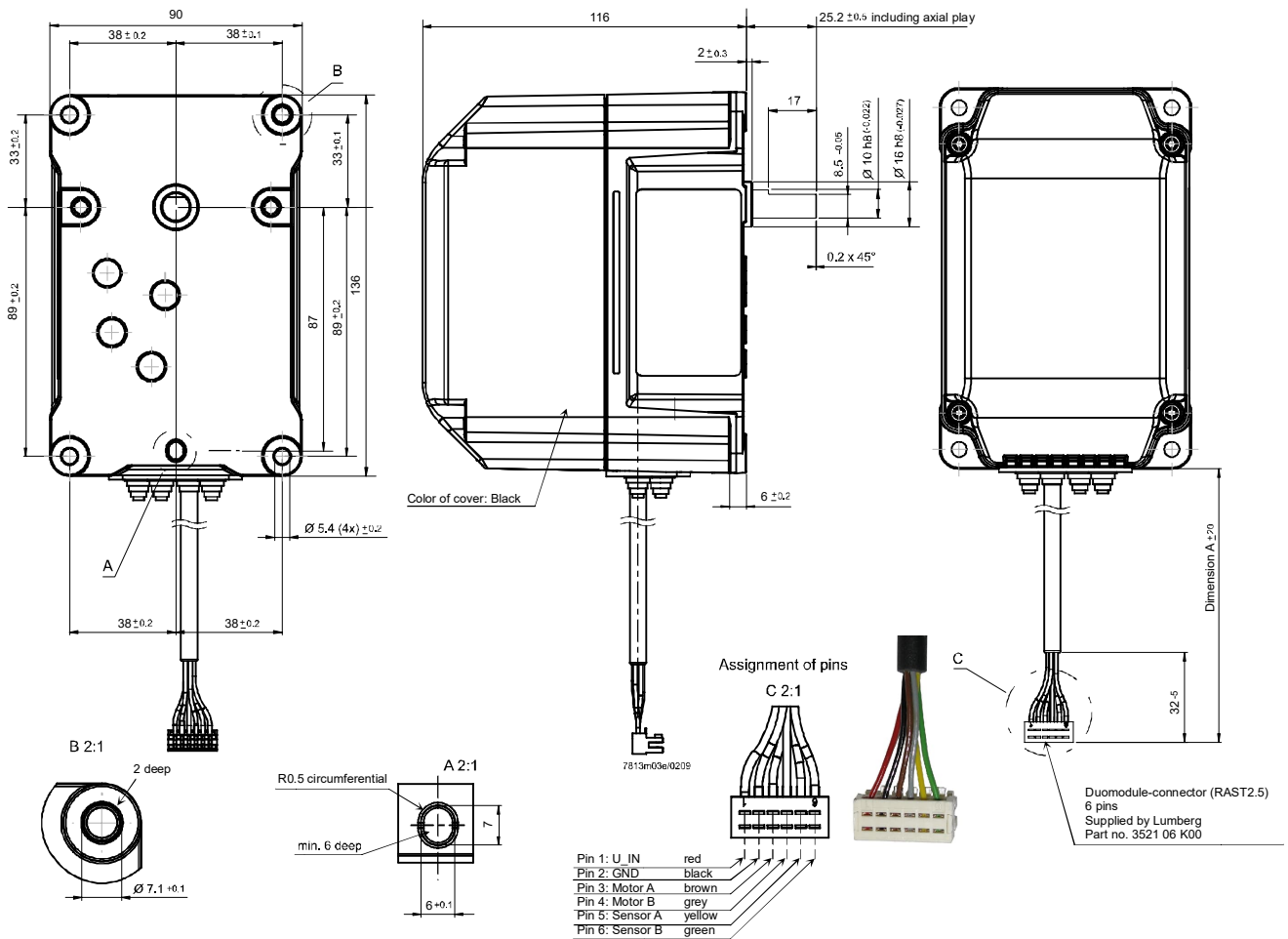

Product No.	Dimension A
SQM33.410A9	1500
SQM33.411A9	3000
SQM33.510A9	1500
SQM33.511A9	3000
SQM33.711A9	3000

Dimensions (cont'd)

Dimensions in mm

SQM33.550A9 / SQM33.750A9

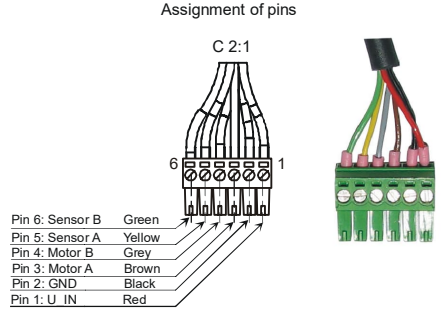
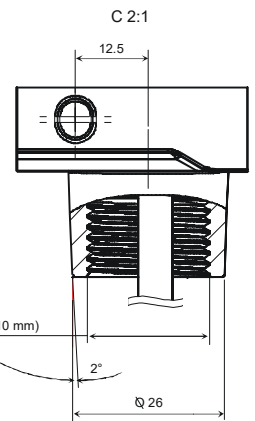
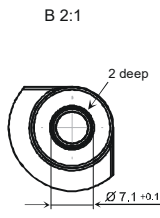
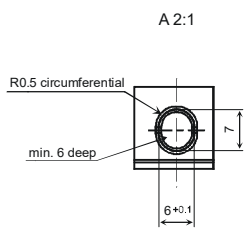
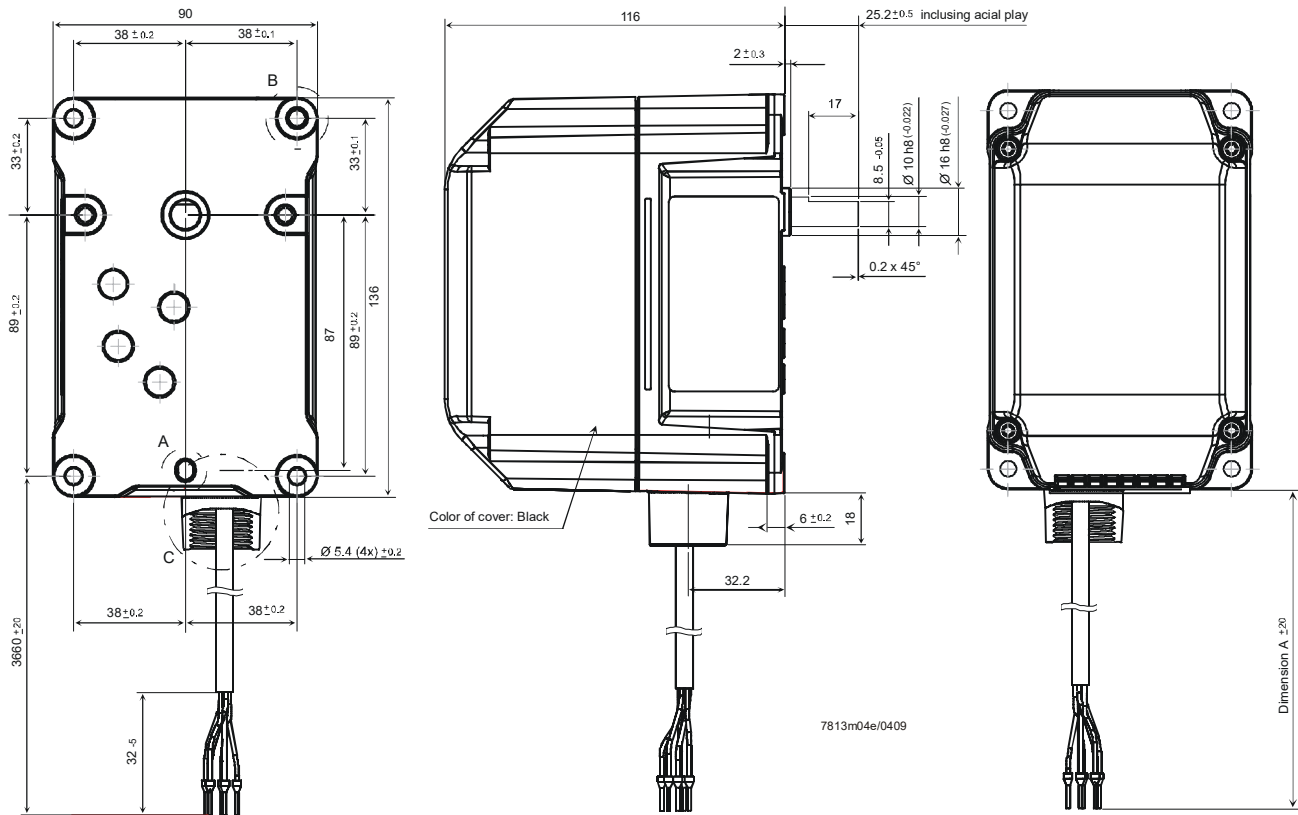

Note!
 The connector assignment with the RAST2.5 connector is the same as with the RAST3.5 connector.

Product No.	Dimension A
SQM33.550A9	3600
SQM33.750A9	3600

For mounting the SQM33 onto the VKP proportional controlling element

Step 1:

- Loosen the screws (M5)
- Remove the plate in the direction of the arrow

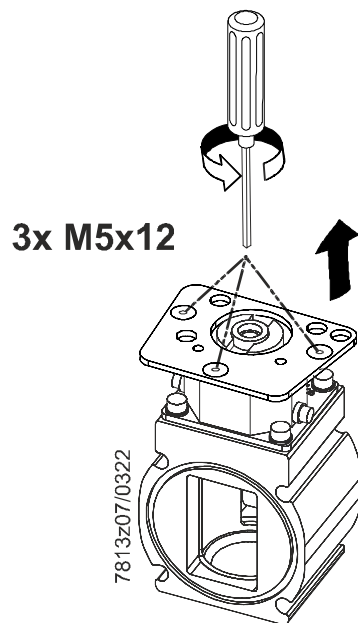

Step 2:

- Loosen the screws (1)
- Pull the plate in the direction of the arrow (2) and remove the reducing sleeve (3)

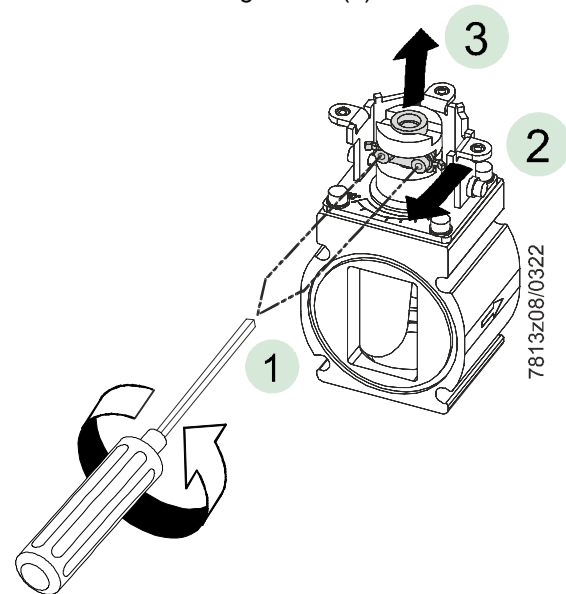

Step 3:

- Place the ASK33.1 mounting plate in the direction of the arrow
- Tighten the screws (M5)

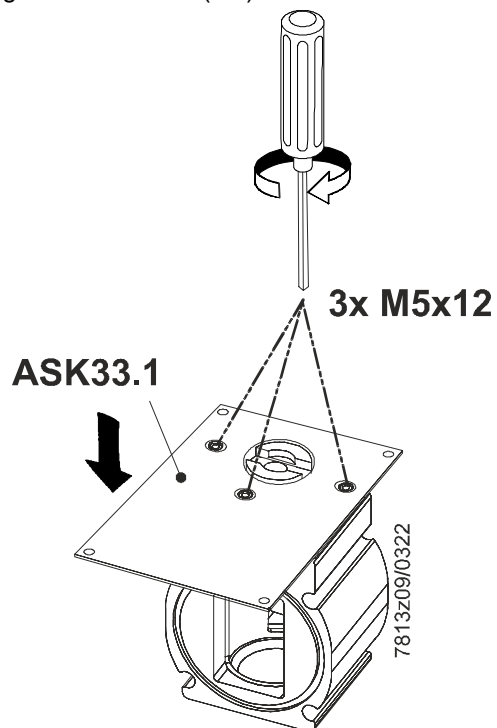

For mounting the SQM33 onto the VKP proportional controlling element (continued)**Step 4:**

- Loosen the screws (1)
- Pull the plate in the direction of the arrow (2) and mount the SQM33

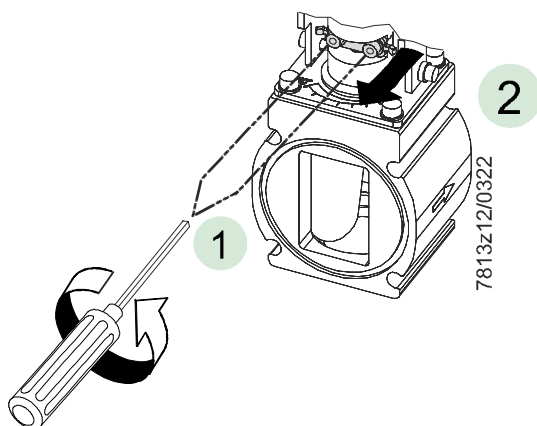
**Step 5:**

Position the SQM33

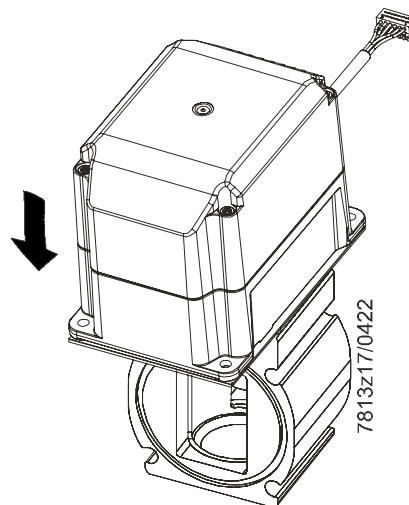
**Step 6:**

Tighten the screws

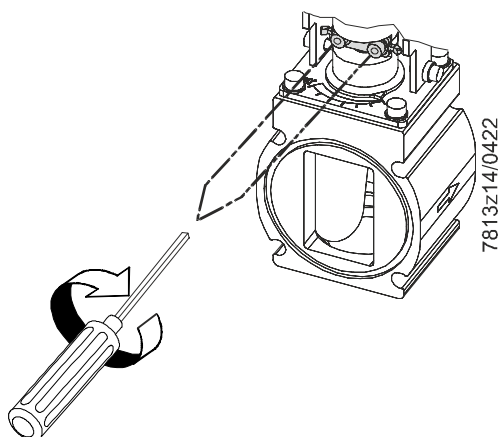
**Step 7:**

Screw the SQM33 onto the plate

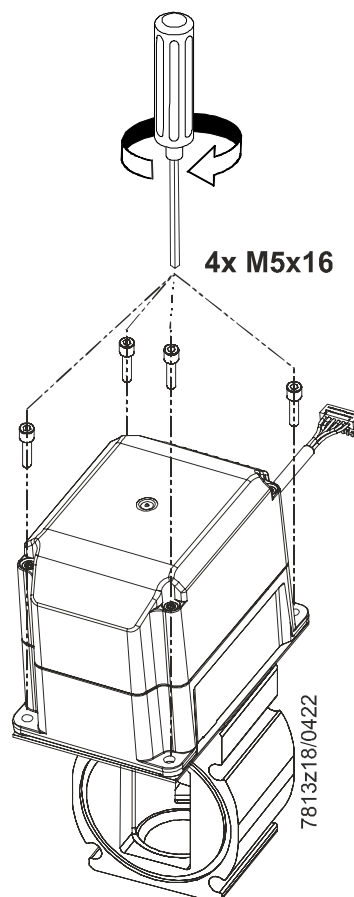

Fitting the SQM33 on the VKF1x butterfly valve

VKF10 / VKF11

VKF10/VKF11 contents

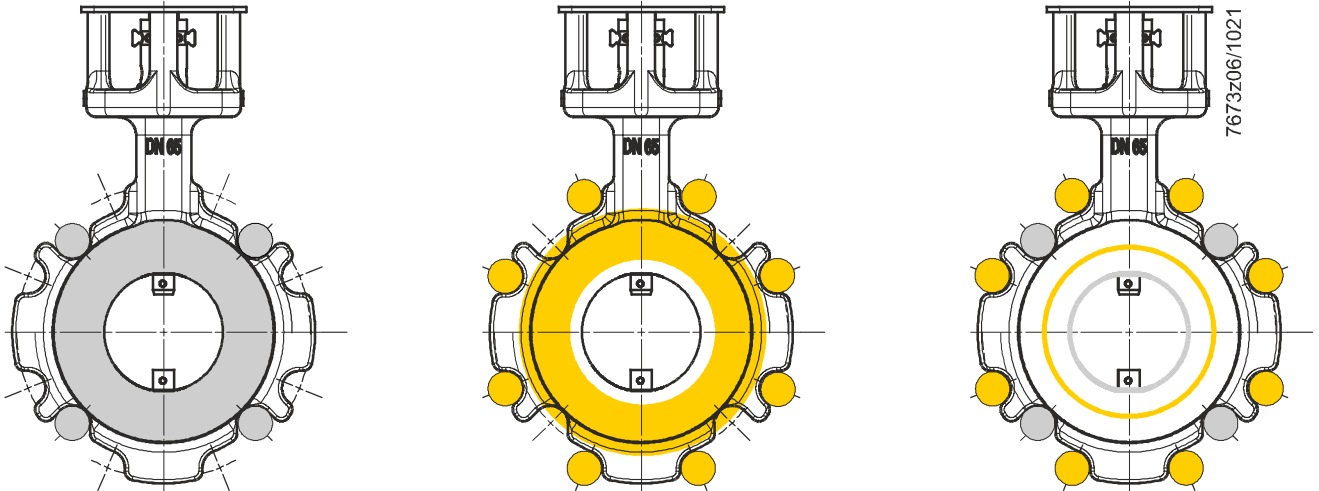
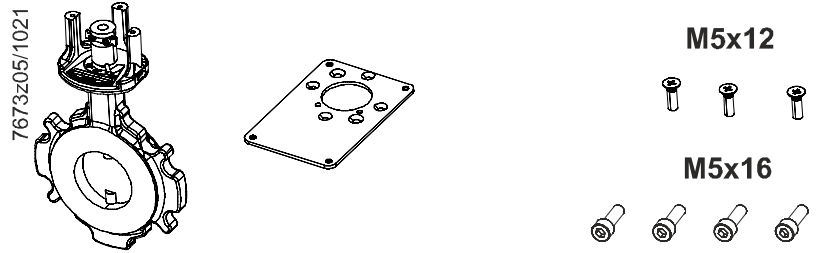

Nominal size DN	Swing thru	With mechanical stop	Suitable for flange size	Tightening torque	Mounting			
					DN ISO	DN ASME	DN+1 ISO	DN+1 ASME
32	VKF10.032	VKF11.032	DN32 + DN40	50 Nm	4 x M16	4 x ½	4 x M16	4 x ½
40	VKF10.040	VKF11.040	DN40 + DN50	50 Nm	4 x M16	4 x ½	4 x M16	4 x 5/8
50	VKF10.050	VKF11.050	DN50 + DN65	50 Nm	4 x M16	4 x 5/8	4 x M16	4 x 5/8
65	VKF10.065	VKF11.065	DN65 + DN80	50 Nm	4 x M16	4 x 5/8	8 x M16	4 x 5/8
80	VKF10.080	VKF11.080	DN80 + DN100	50 Nm	8 x M16	4 x 5/8	8 x M16	8 x 5/8
100	VKF10.100	VKF11.100	DN100 + DN125	80 Nm	8 x M16	8 x 5/8	8 x M16	8 x ¾
125	VKF10.125	VKF11.125	DN125 + DN150	160 Nm	8 x M16	8 x ¾	8 x M20	8 x ¾
150	VKF10.150	VKF11.150	DN150 + DN200	160 Nm	8 x M20	8 x ¾	12 x M20	8 x ¾
200	VKF10.200	VKF11.200	DN200	160 Nm	12 x M20	8 x ¾	---	---

Fitting the SQM33 on the VKF1x butterfly valve (continued)

Mounting position of the mounting plate

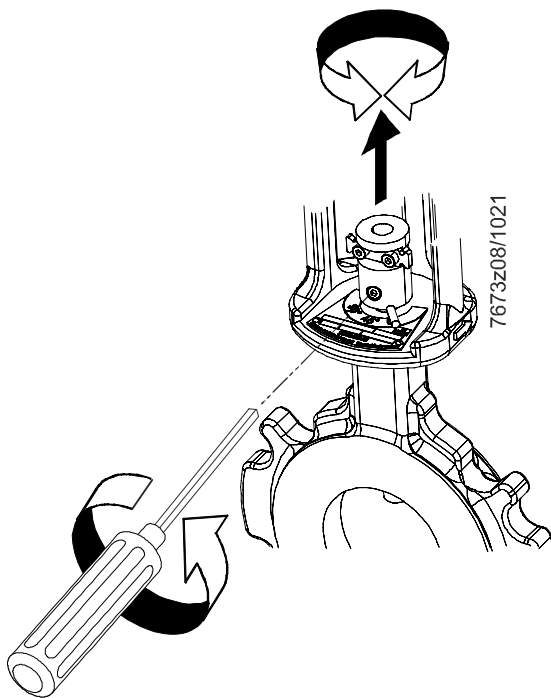
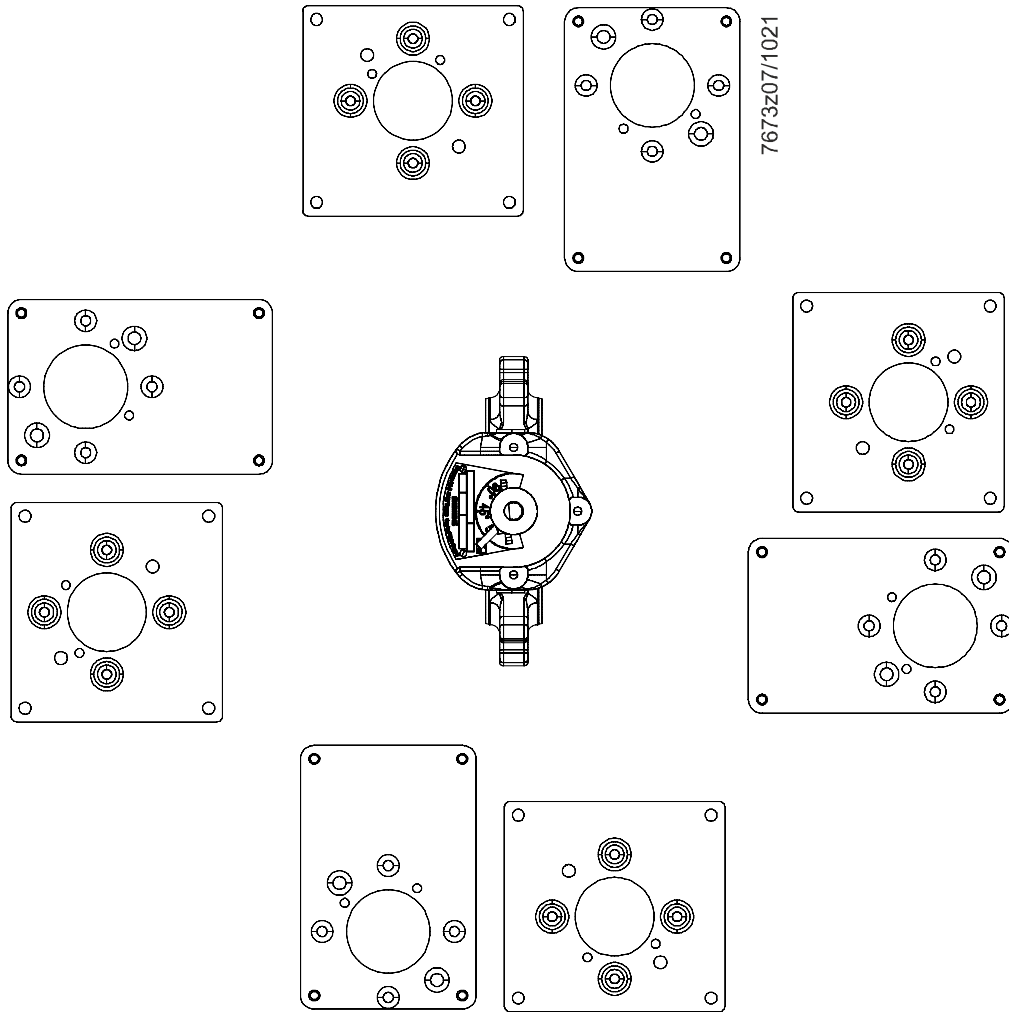

Loosen the screw. Align the coupling to suit the mounting position of the mounting plate. Tighten the screw again (max. 2 Nm).

Fitting the SQM33 on the VKF1x butterfly valve (continued)

Step 1:

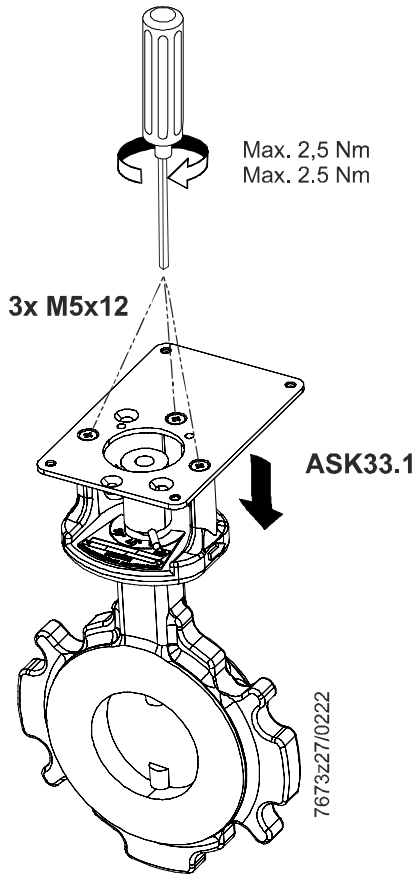

Step 2:

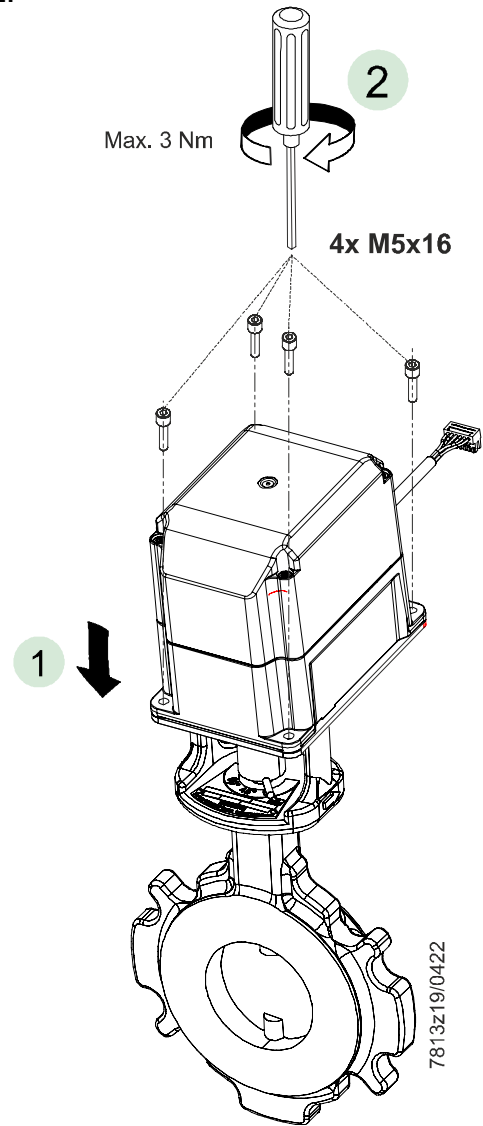

Step 3:

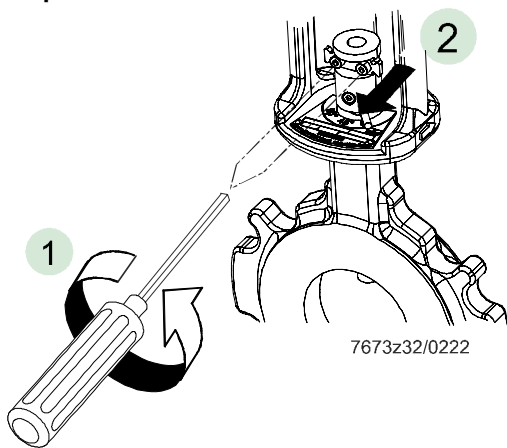

- 1 Loosen the screws.
- 2 Pull the plate in the direction of the arrow and mount the SQM33

Step 4:

